

ISC - LHR

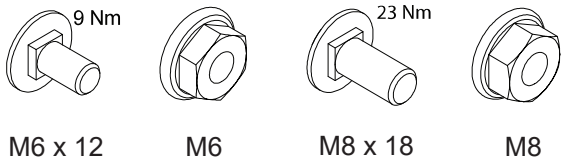



M6 x 12 M6 M8 x 18 M8

VAGY / OR

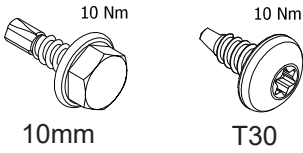

10mm T30



KLING- 2021.02.22.

1

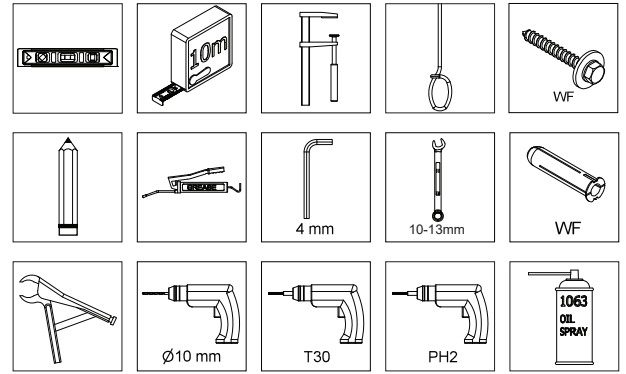

KLING- 2021.02.22.

2

NL12

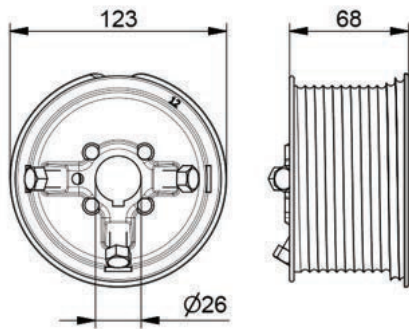

KLING- 2021.02.22.

3

NL18

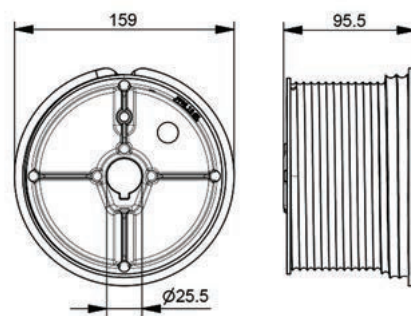

KLING- 2021.02.22.

4

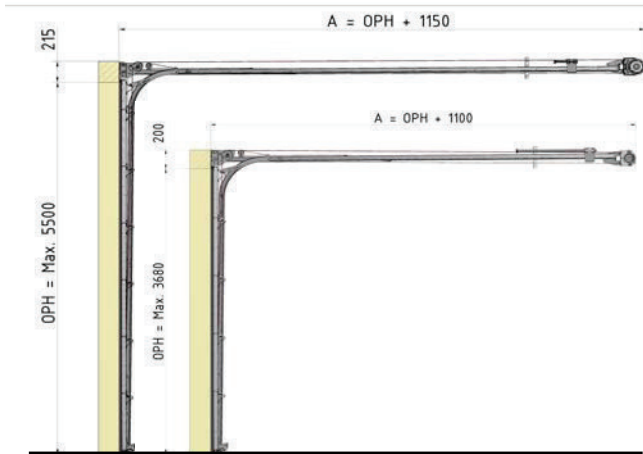

KLING- 2021.02.22.

5

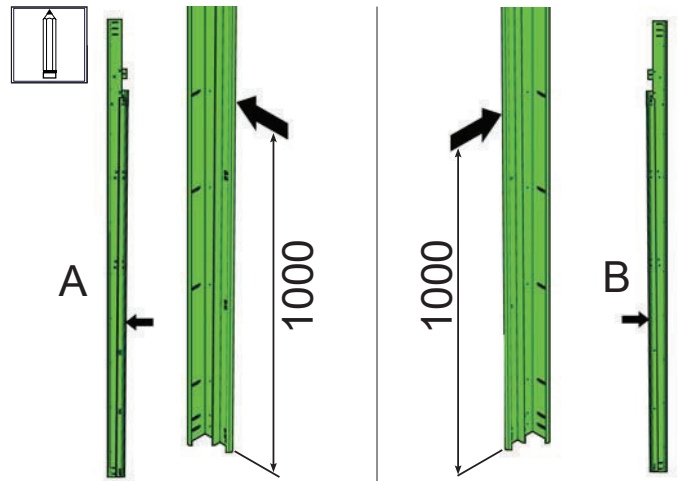

KLING- 2021.02.22.

6

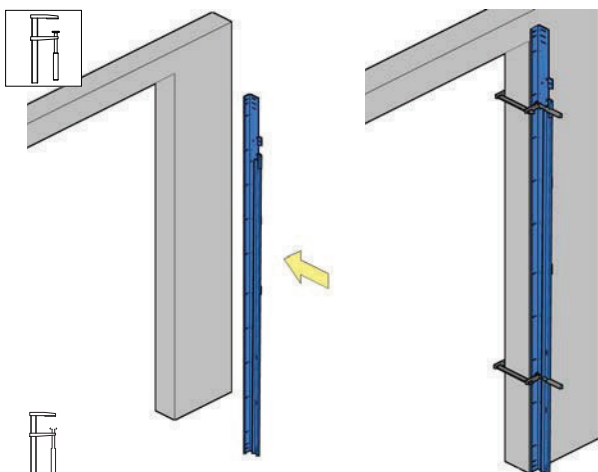

KLING- 2021.02.22.

7

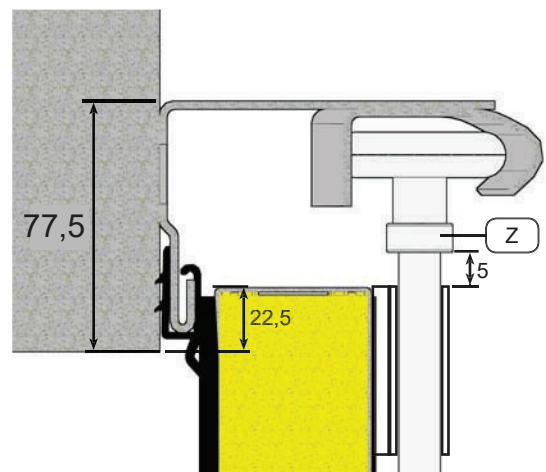

KLING- 2021.02.22.

8

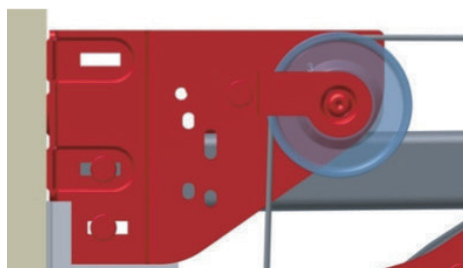
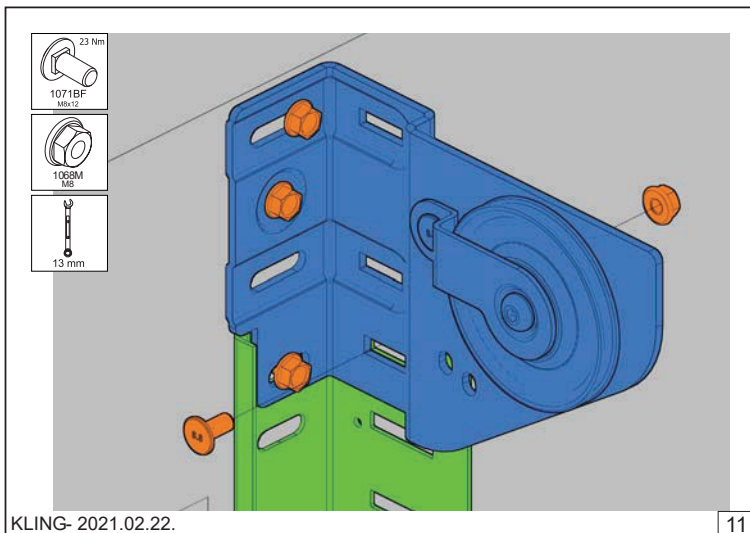
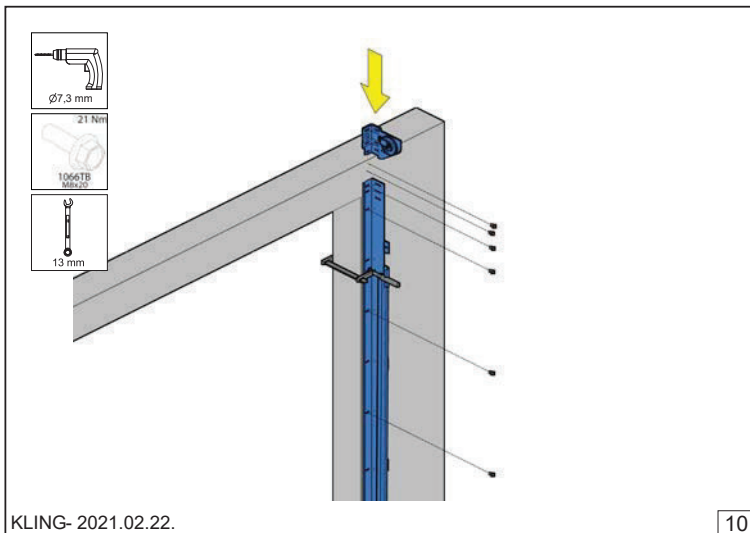
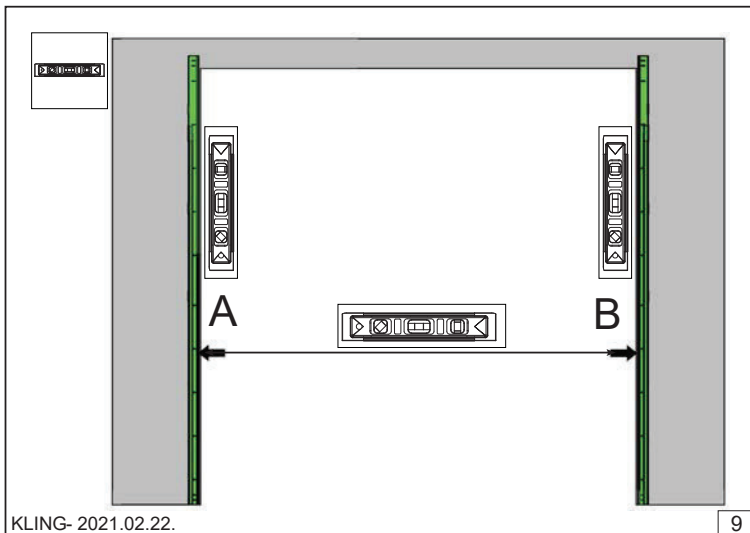

Kábeltartócsa 1. pozíció
Cable pulley position 1

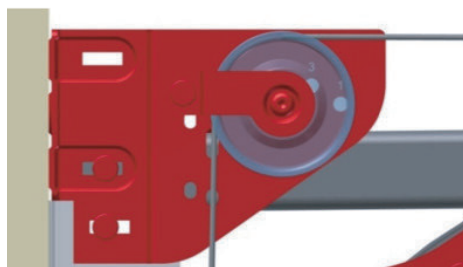

Kábeltartócsa 2. pozíció
Cable pulley position 2

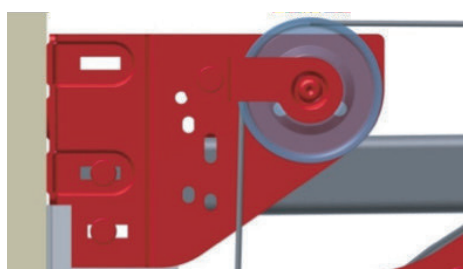

Kábeltartócsa 3. pozíció
Cable pulley position 3

	FFNL12		FFNL18	
	Áthidaló magasság / Built-in heigh	Szabad átjárható magasság / Free opening space	Áthidaló magasság / Built-in heigh	Szabad átjárható magasság / Free opening space
1. pozíció Position 1	200mm*	-0mm	225mm*	-0mm
2. pozíció Position 2	200mm**	-10mm	225mm**	-5mm
3. pozíció Position 3	200mm*	-5mm	225mm*	-0mm

Az optimális telepítéshez különböző pozíciókat lehet használni.
The different positions can be used to optain optimum installation.

* - A kábel érinti a tengelyt (cable touches roller shaft)

** - A kábel nem ér a tengelyhez (cable free from roller shaft)

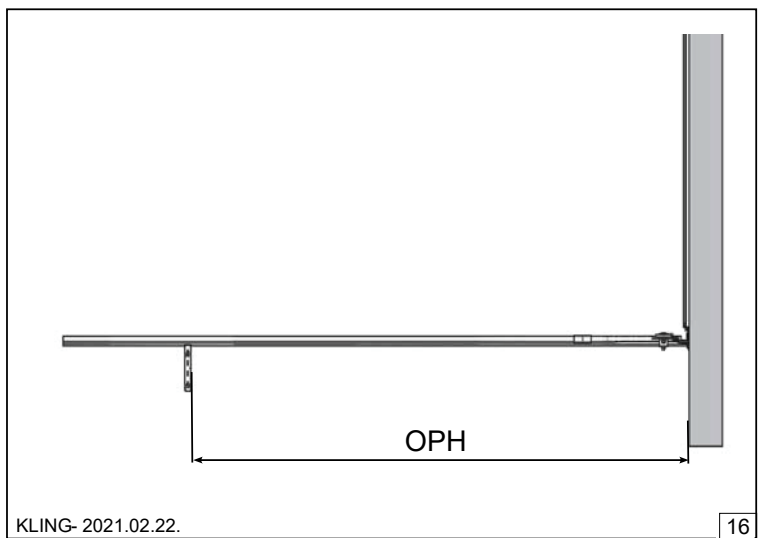
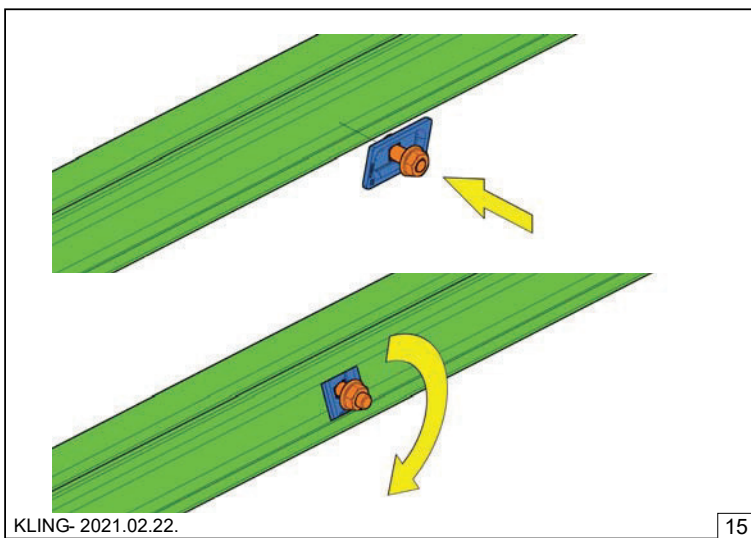
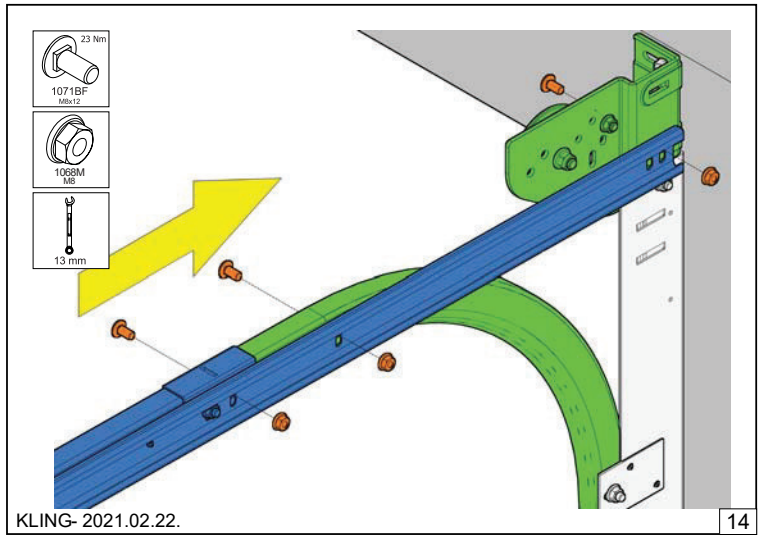
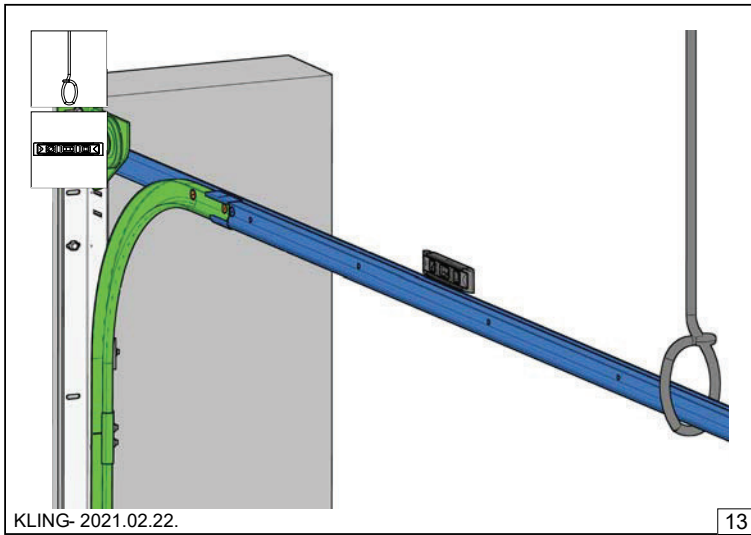

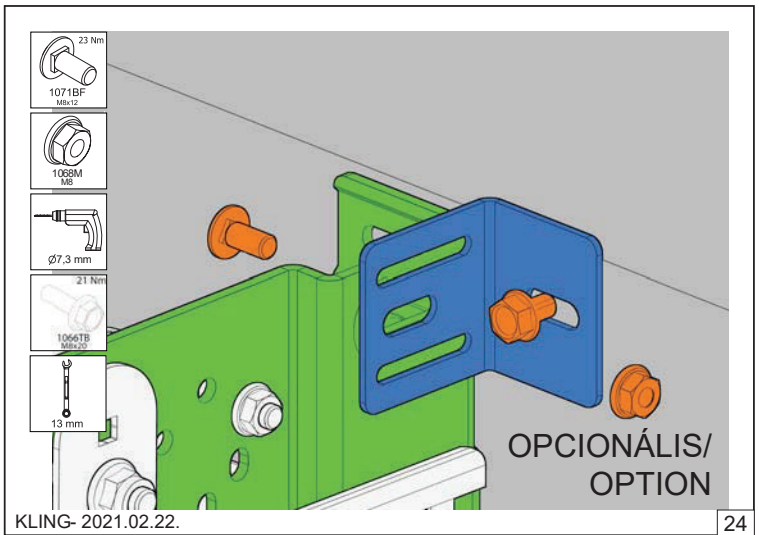
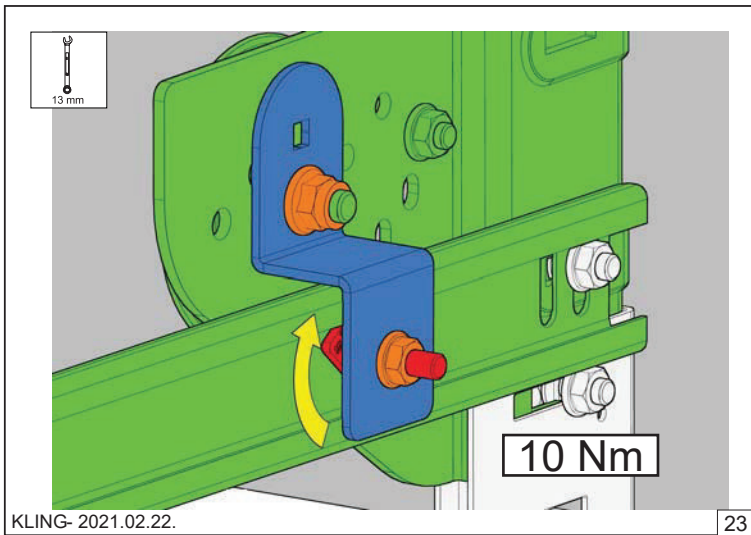
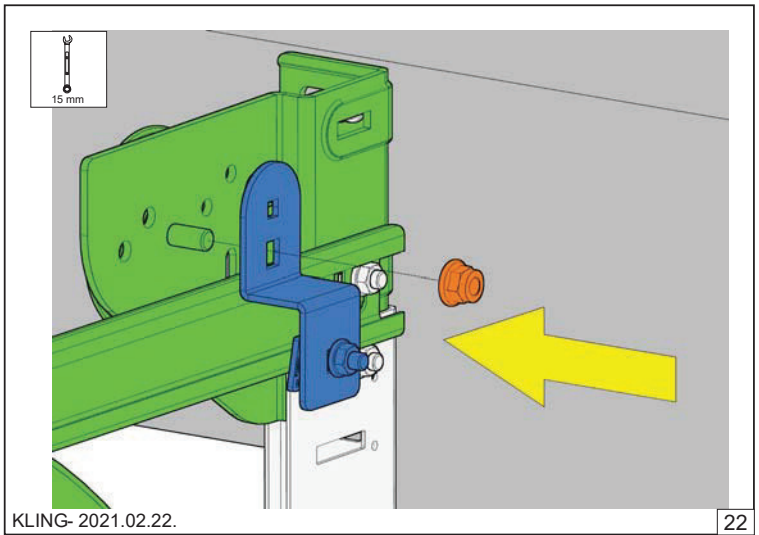
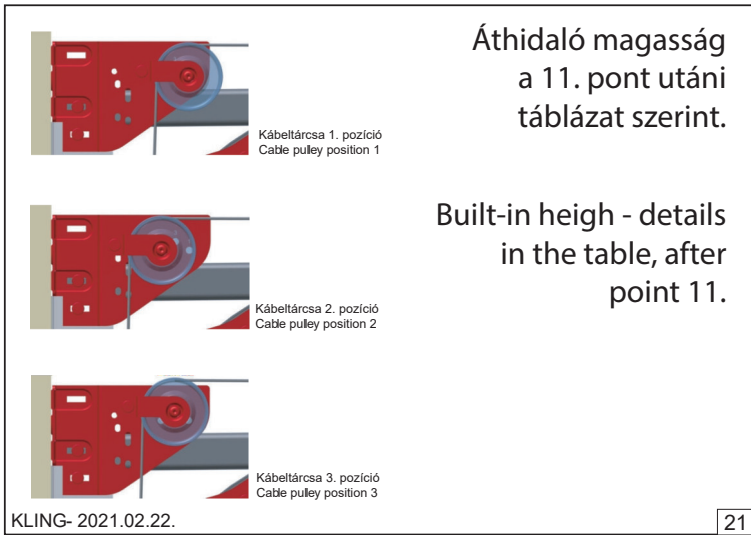
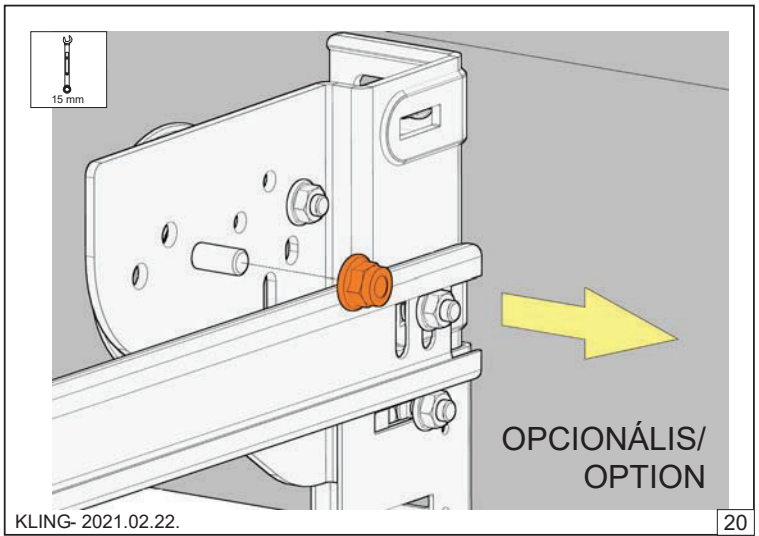
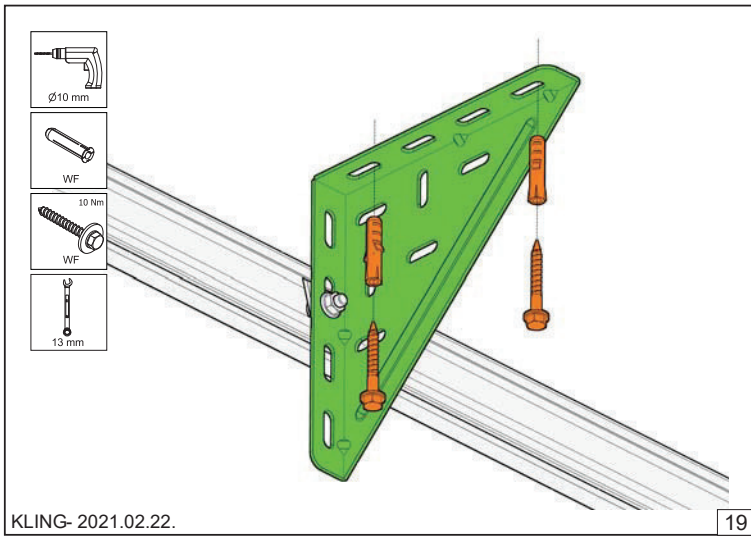
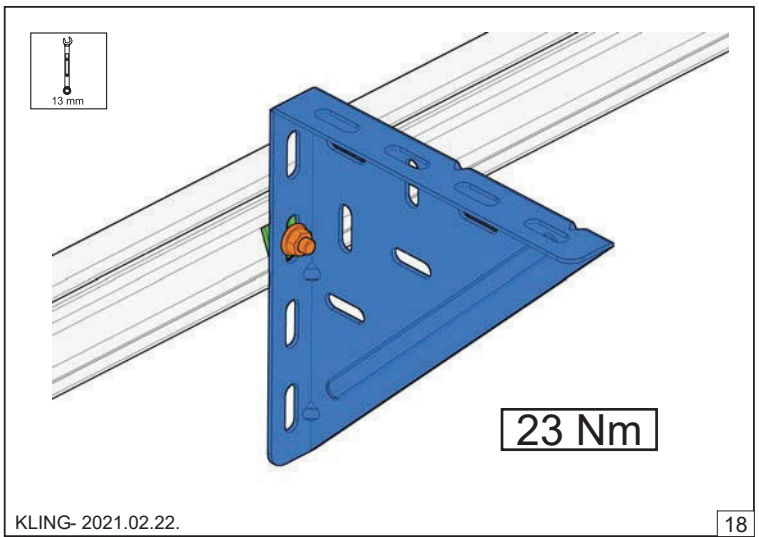
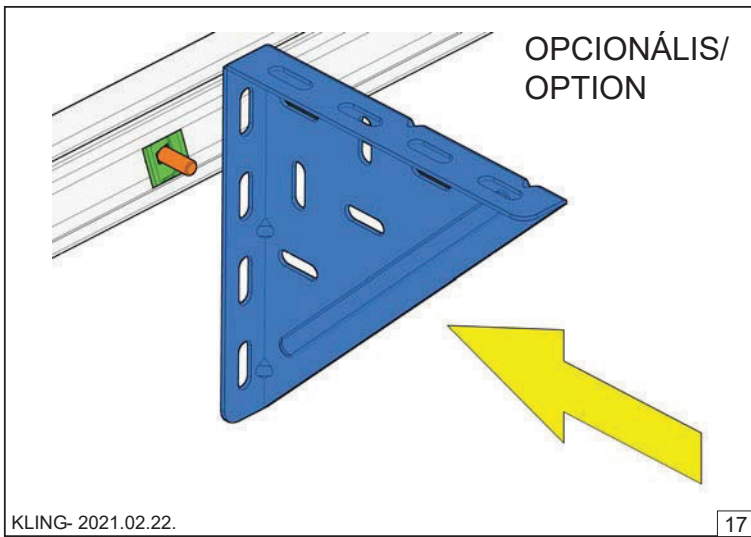

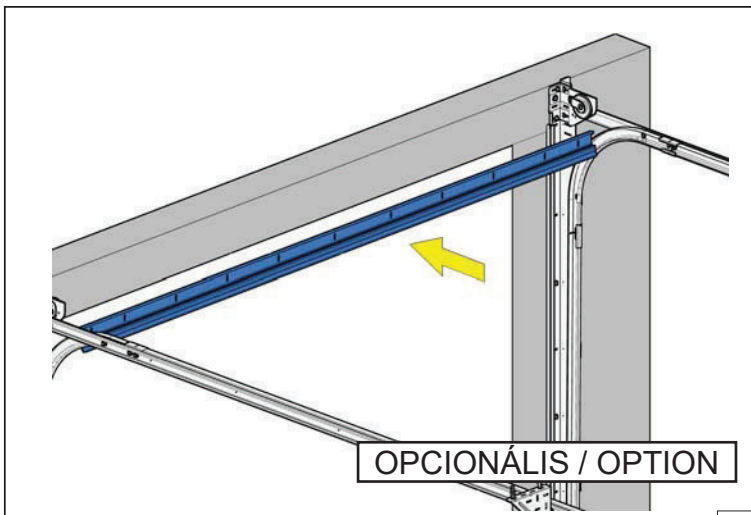

KLING- 2021.02.22.

25

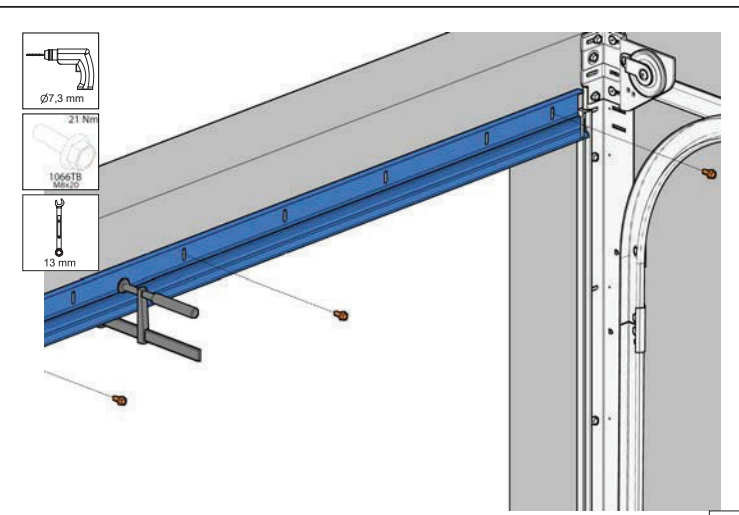

KLING- 2021.02.22.

26

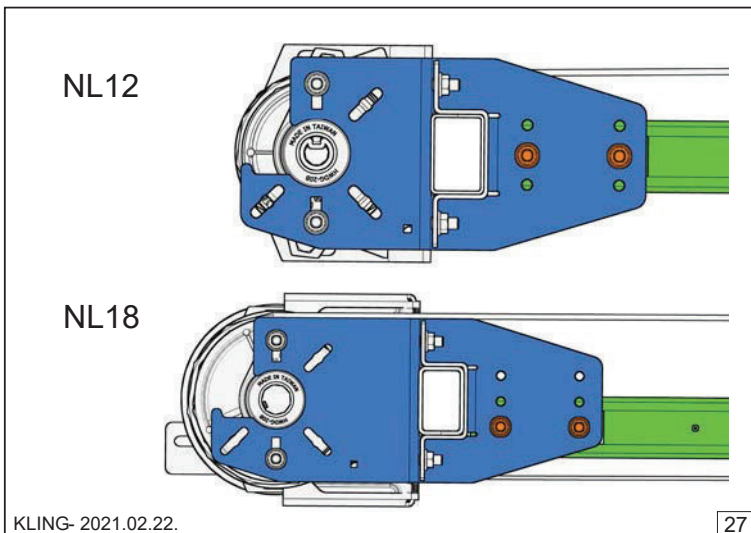

KLING- 2021.02.22.

27

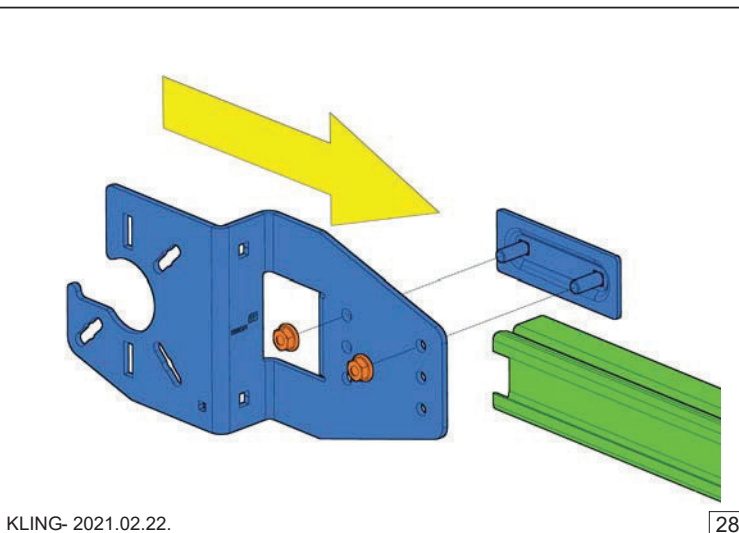

KLING- 2021.02.22.

28

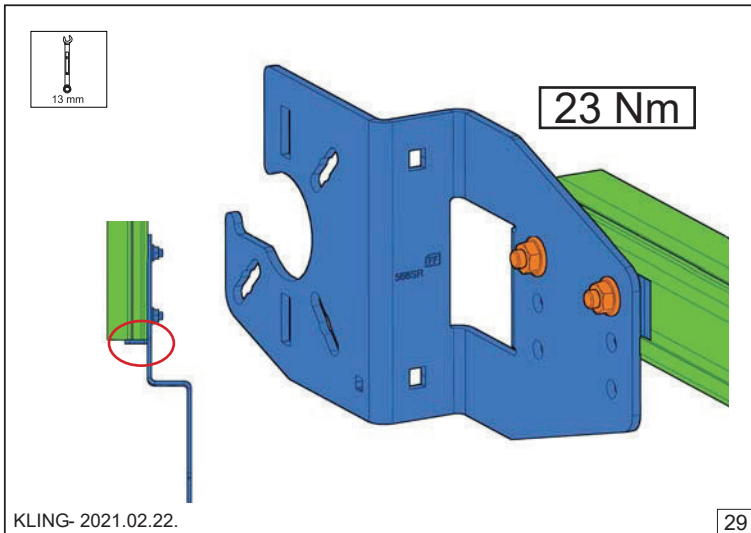

KLING- 2021.02.22.

29

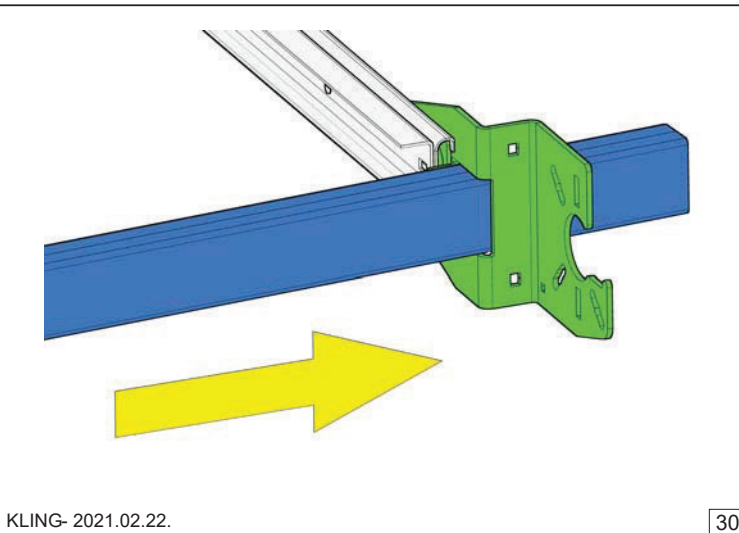

KLING- 2021.02.22.

30

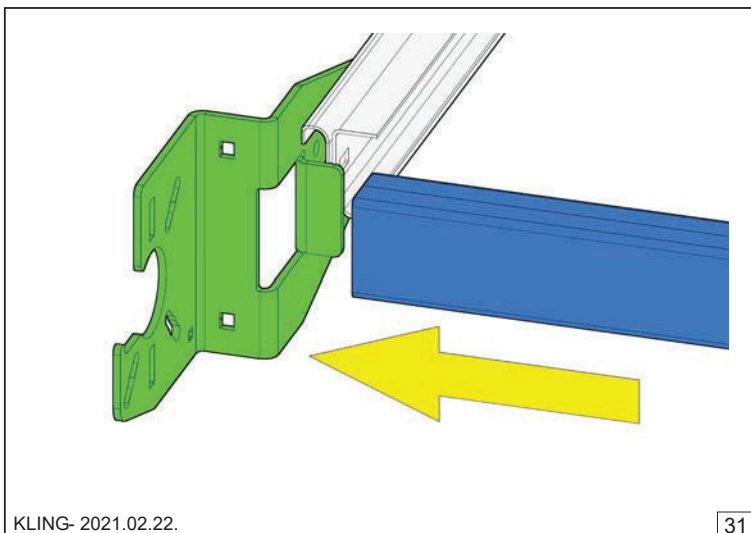

KLING- 2021.02.22.

31

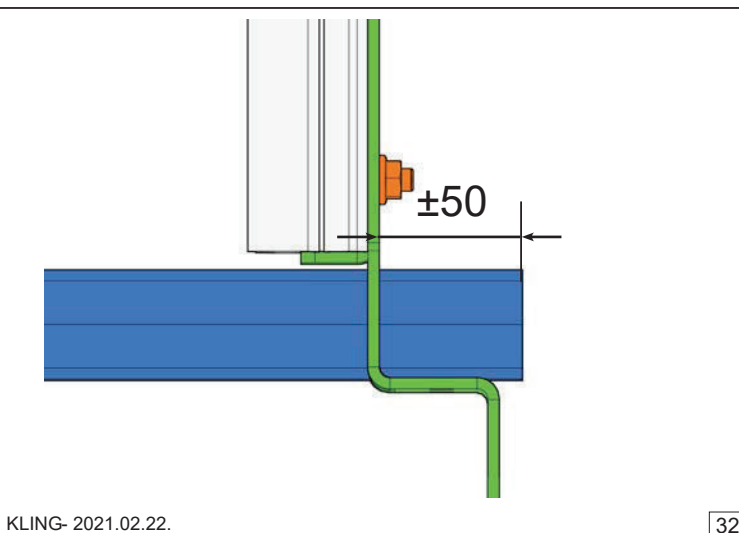

KLING- 2021.02.22.

32

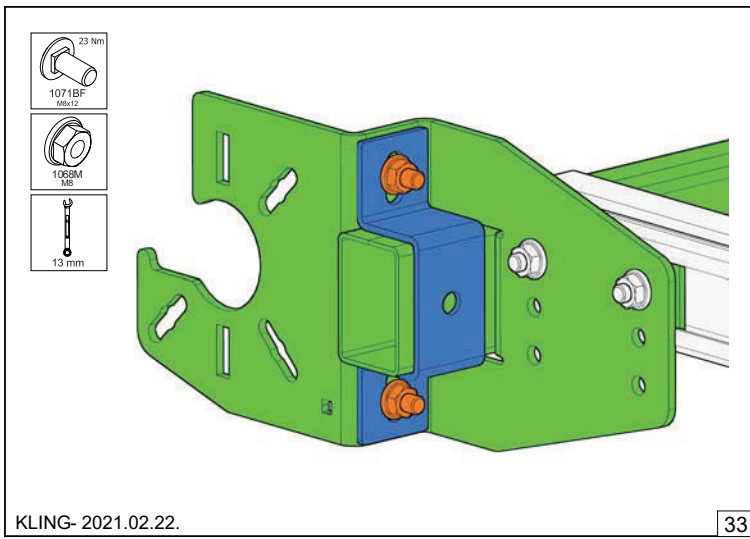

KLING- 2021.02.22.

33

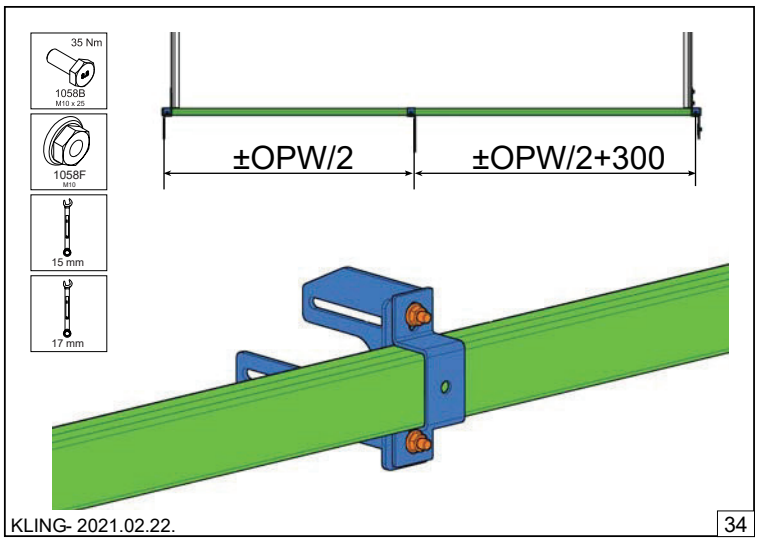

KLING- 2021.02.22.

34

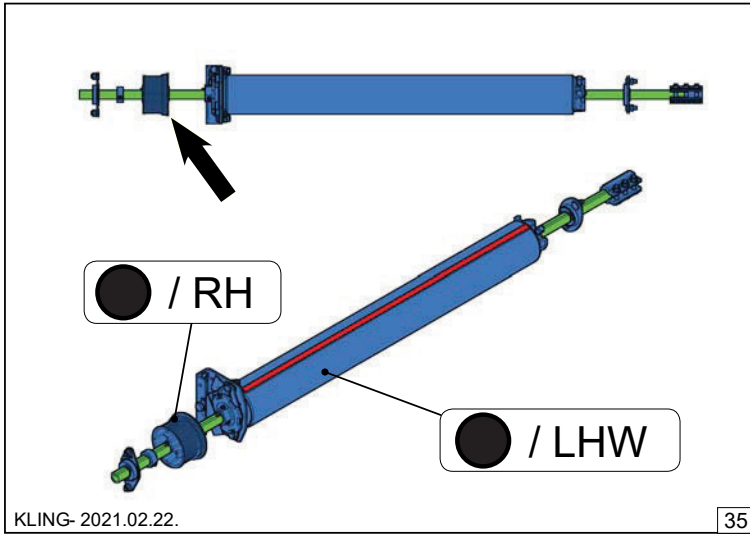

KLING- 2021.02.22.

35

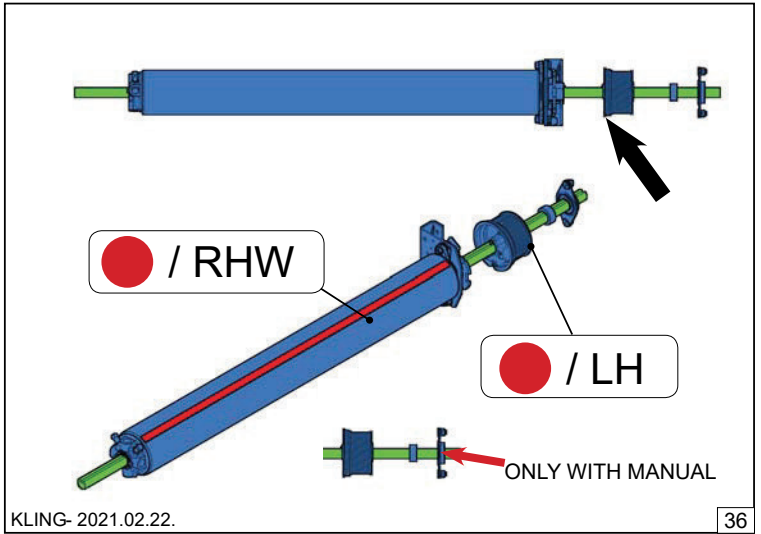

KLING- 2021.02.22.

36

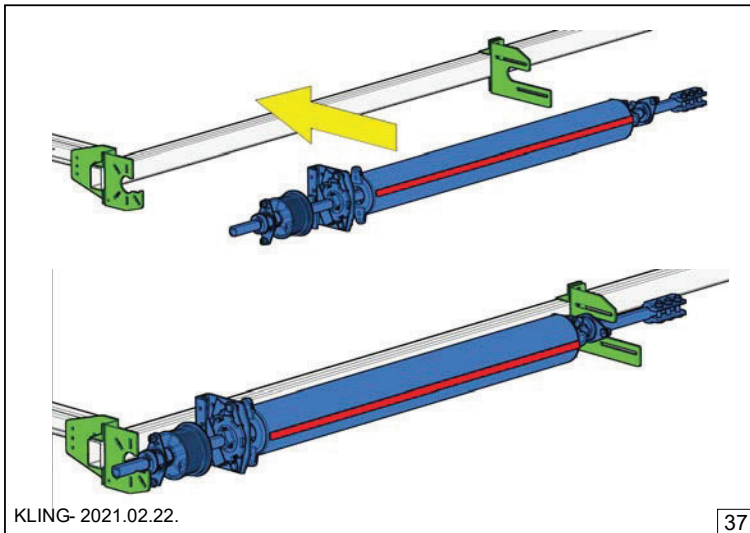

KLING- 2021.02.22.

37

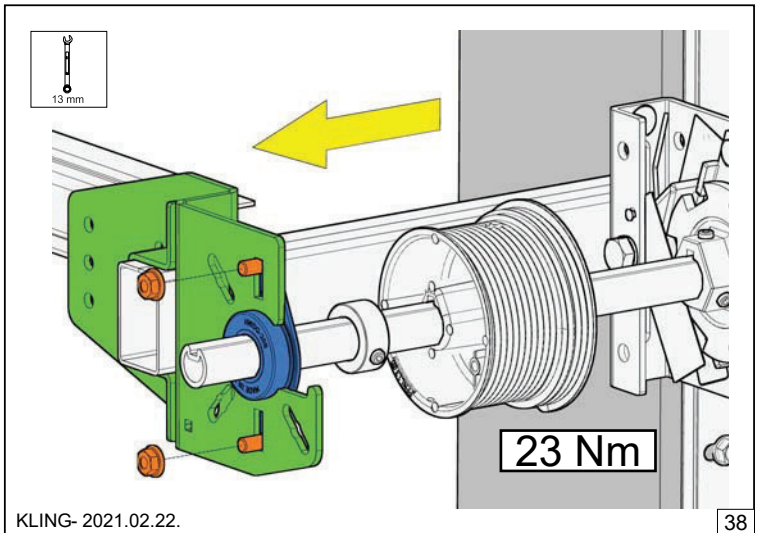

KLING- 2021.02.22.

38

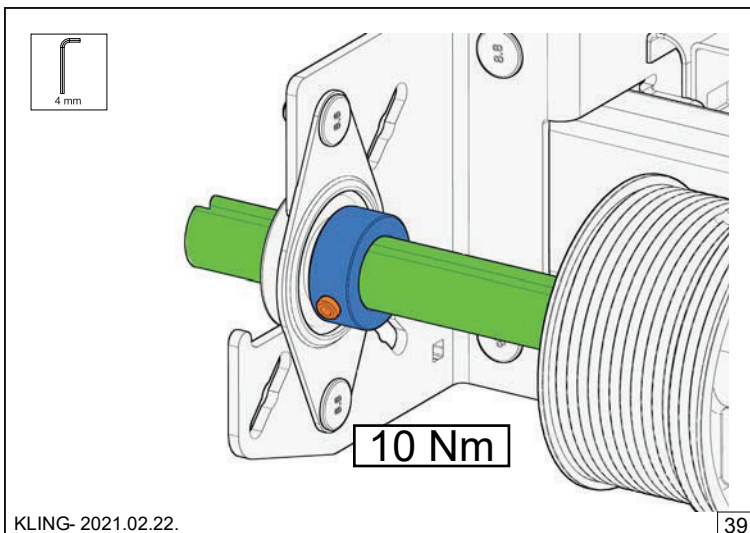

KLING- 2021.02.22.

39

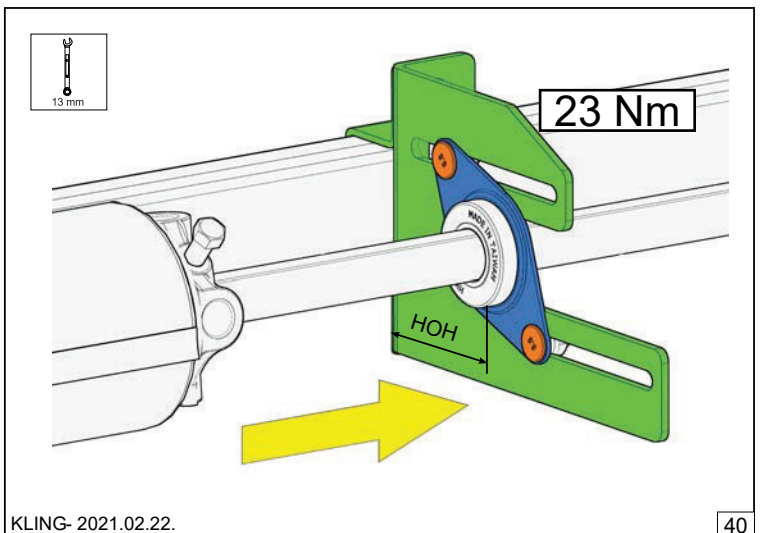

KLING- 2021.02.22.

40

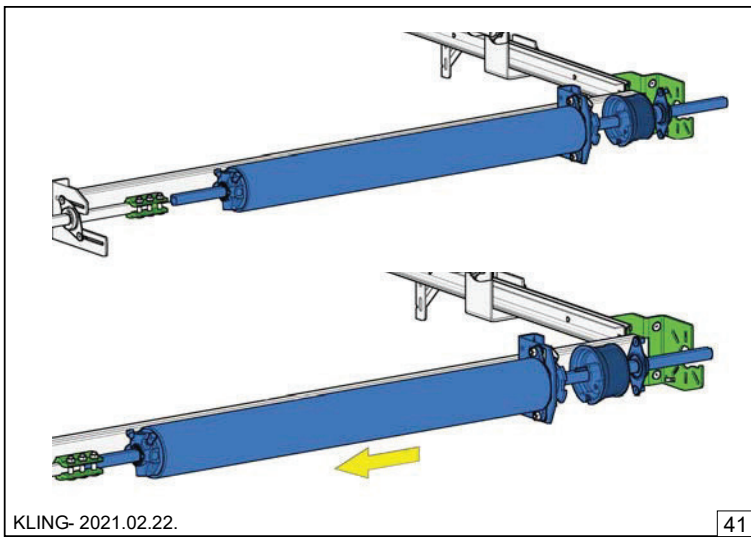

KLING- 2021.02.22.

41

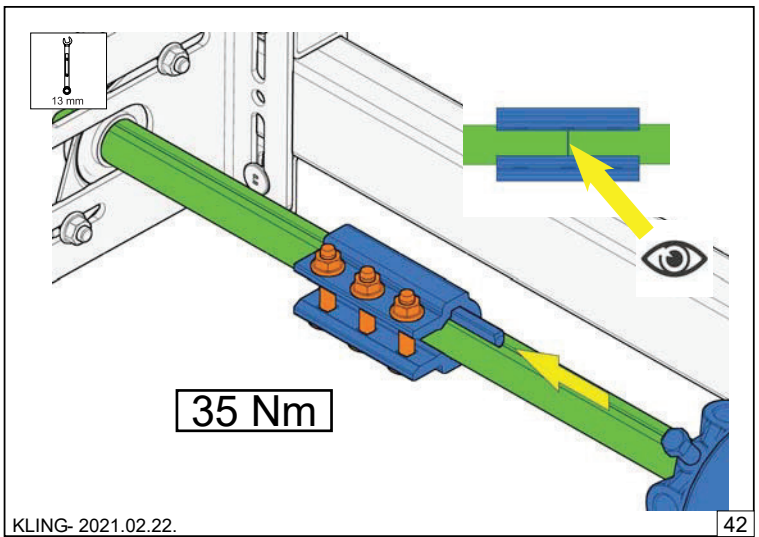

KLING- 2021.02.22.

42

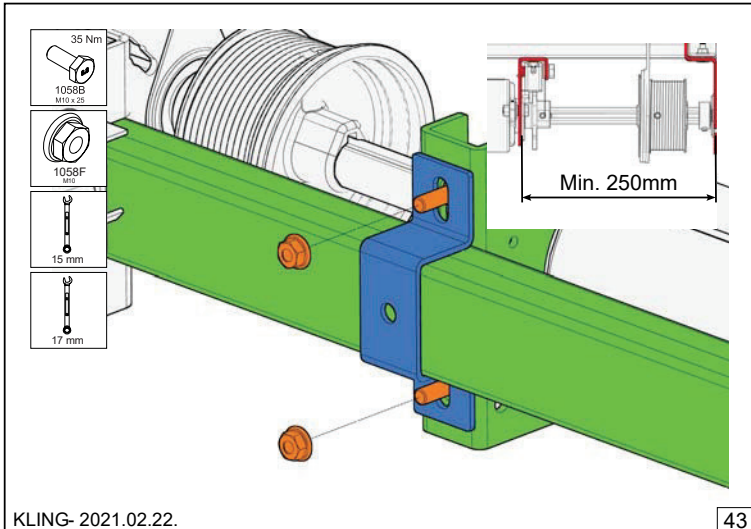

KLING- 2021.02.22.

43

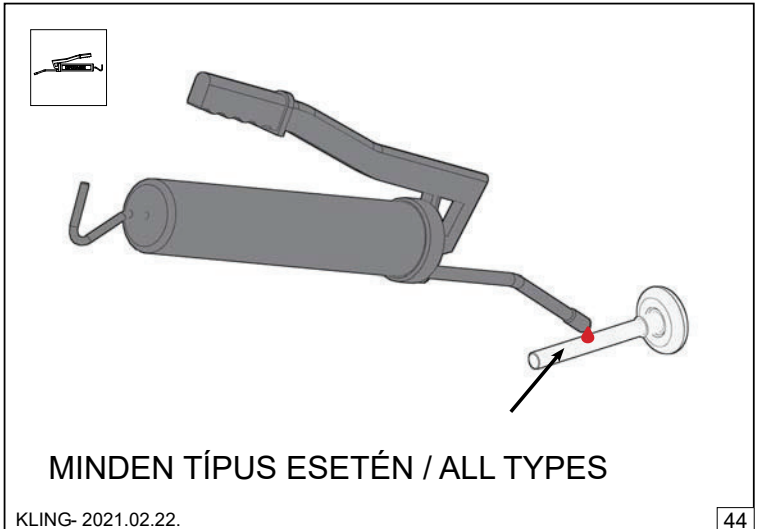

KLING- 2021.02.22.

44

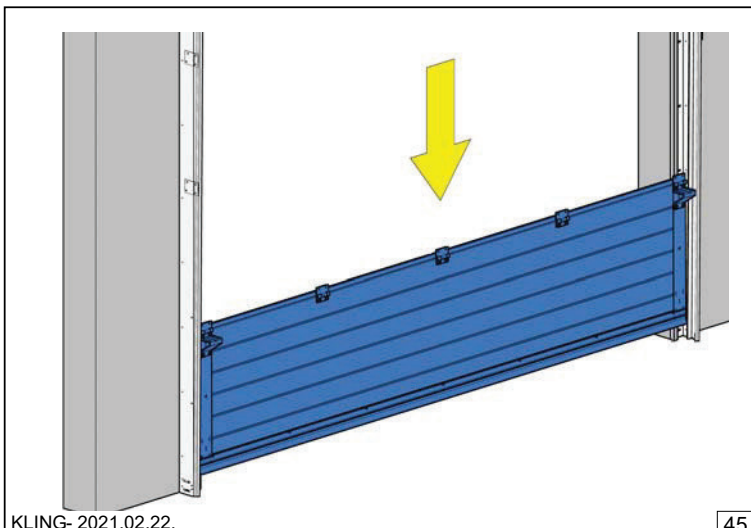

KLING- 2021.02.22.

45

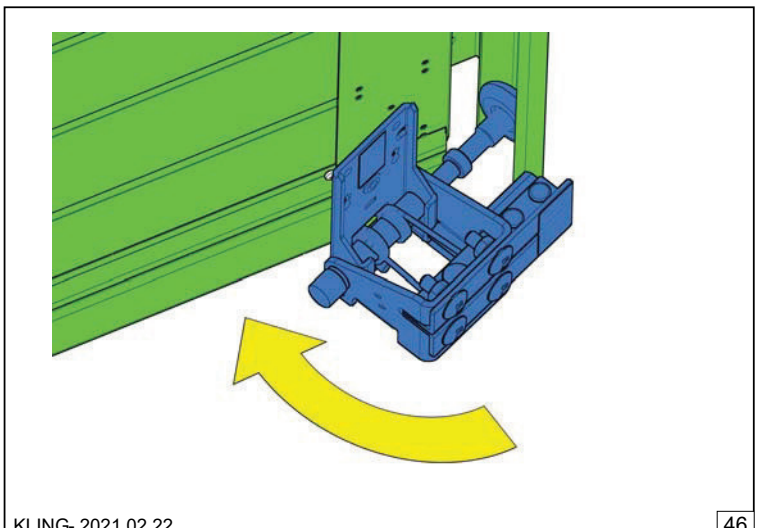

KLING- 2021.02.22.

46

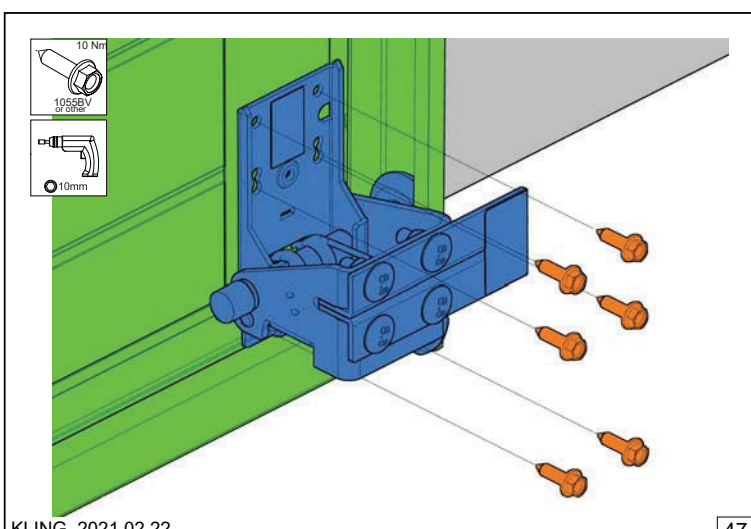

KLING- 2021.02.22.

47

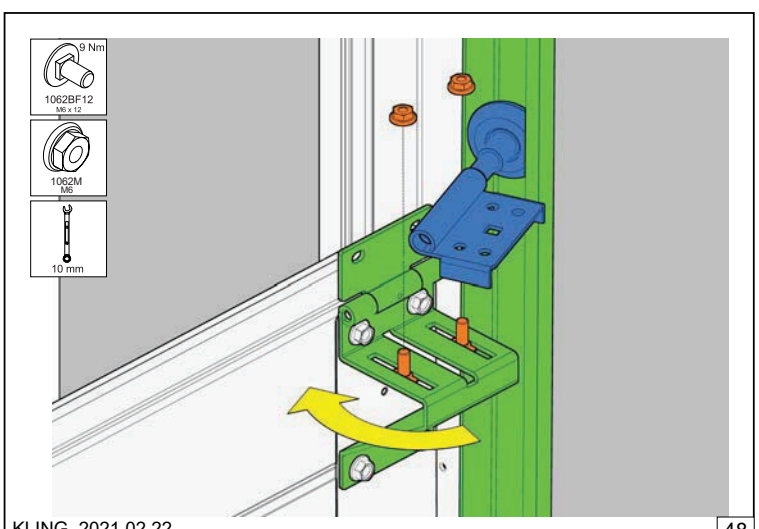

KLING- 2021.02.22.

48

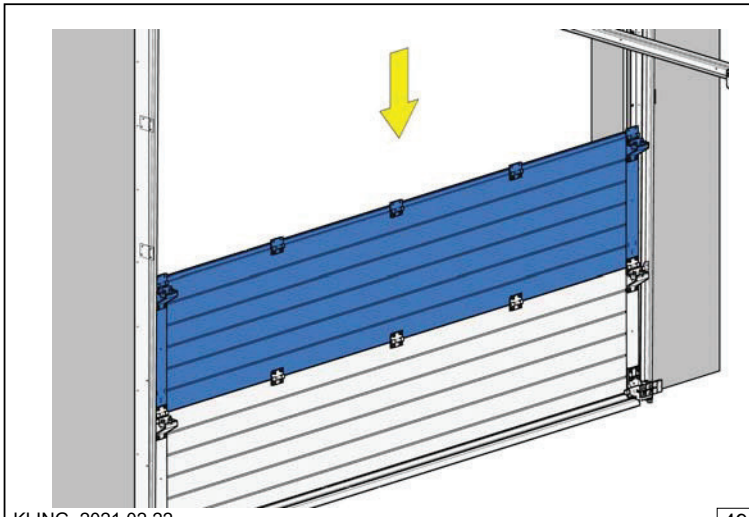

KLING- 2021.02.22.

49

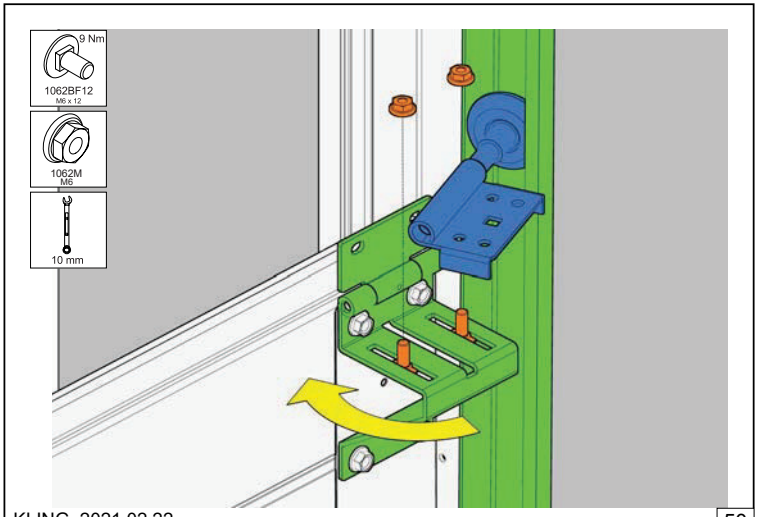

KLING- 2021.02.22.

50

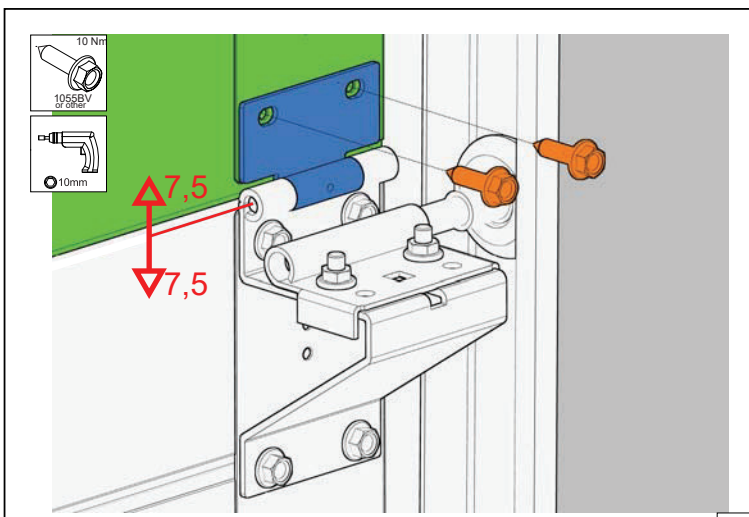

KLING- 2021.02.22.

51

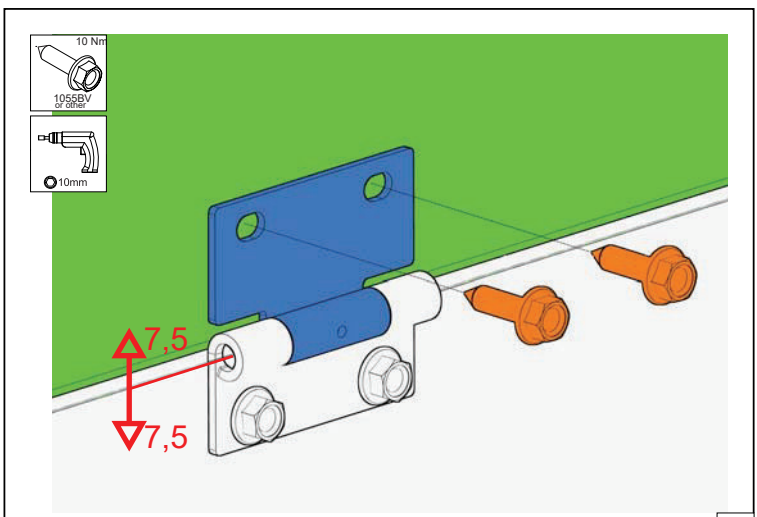

KLING- 2021.02.22.

52

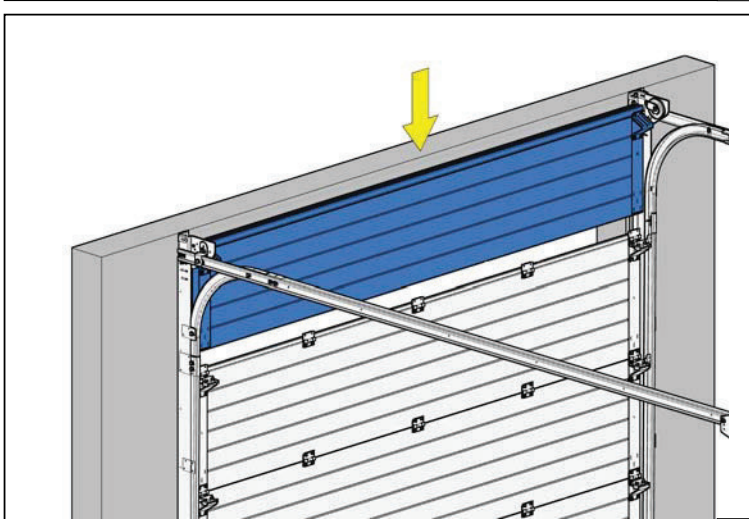

KLING- 2021.02.22.

53

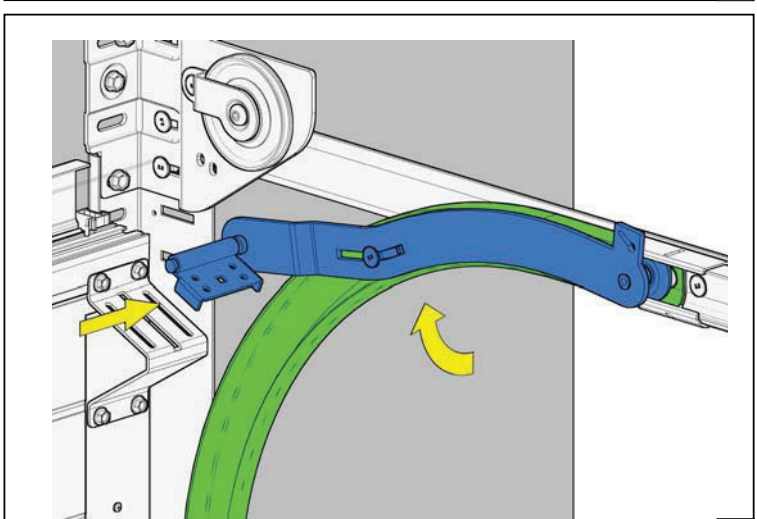

KLING- 2021.02.22.

54

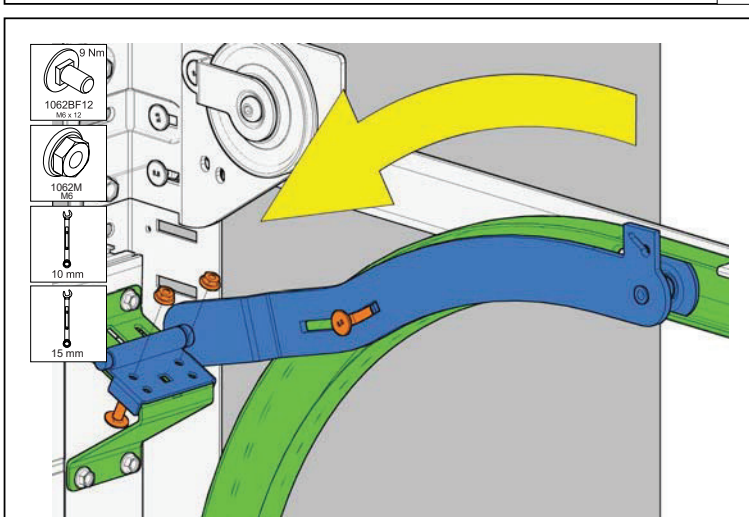

KLING- 2021.02.22.

55

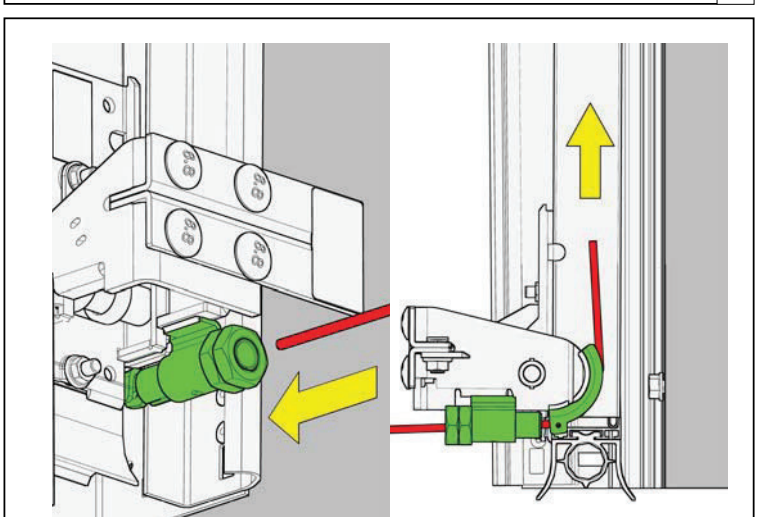

KLING- 2021.02.22.

56

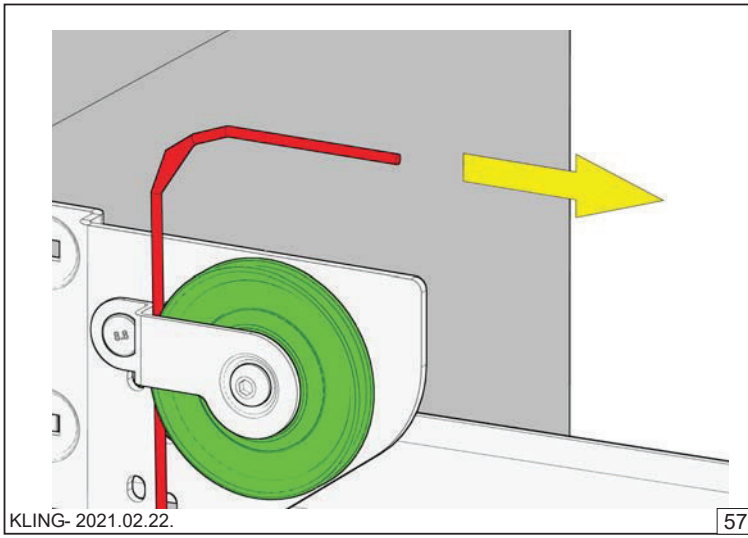

KLING- 2021.02.22.

57

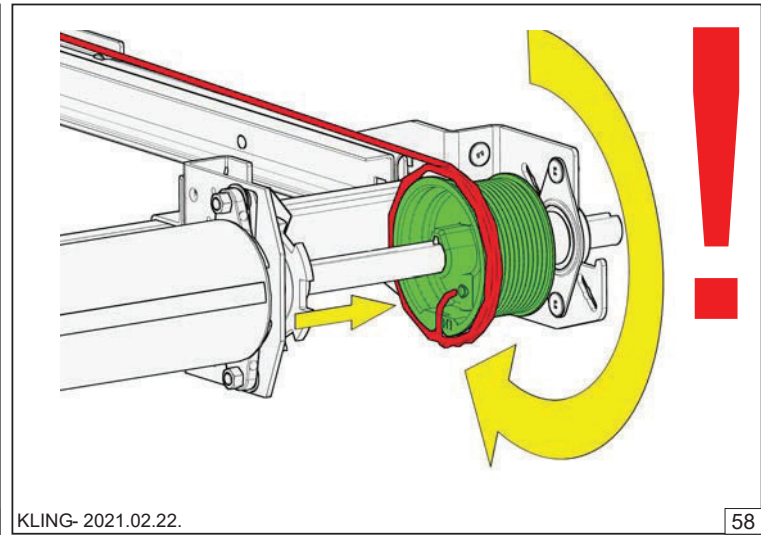

KLING- 2021.02.22.

58

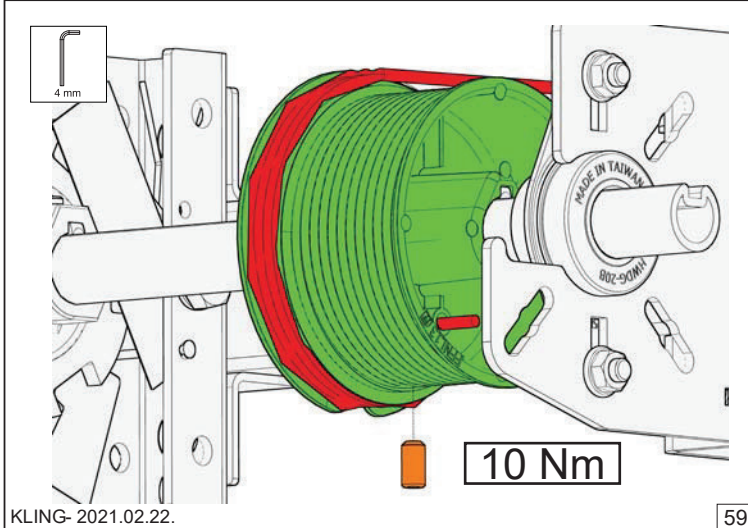

KLING- 2021.02.22.

59

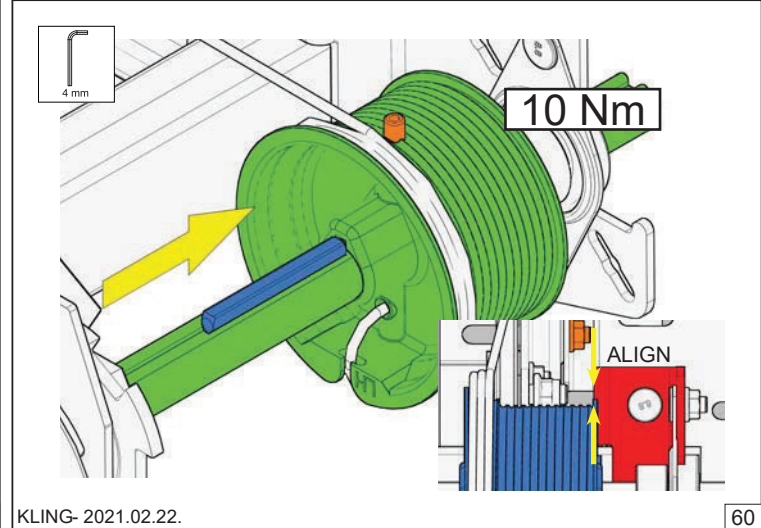

KLING- 2021.02.22.

60

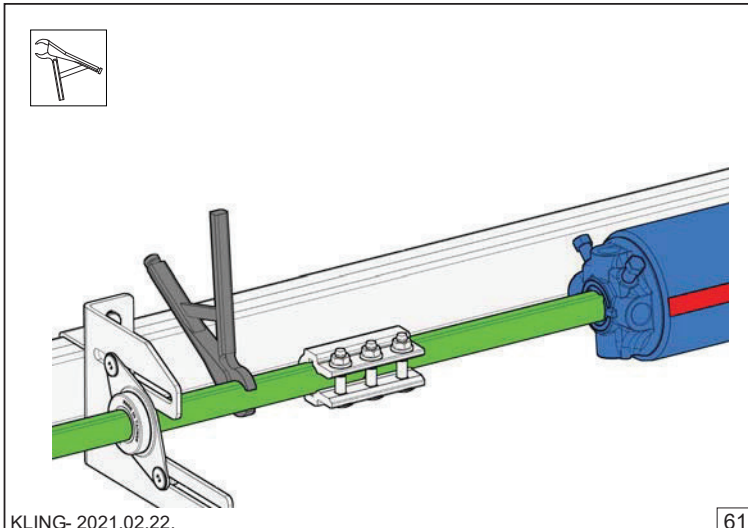

KLING- 2021.02.22.

61

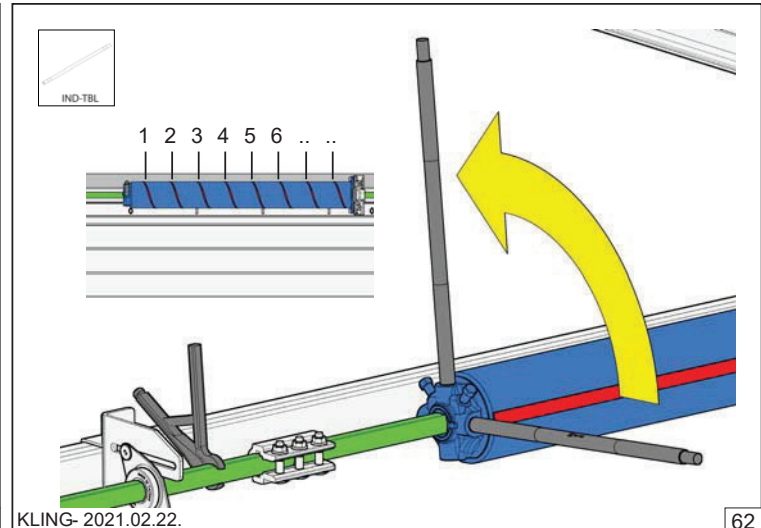

KLING- 2021.02.22.

62

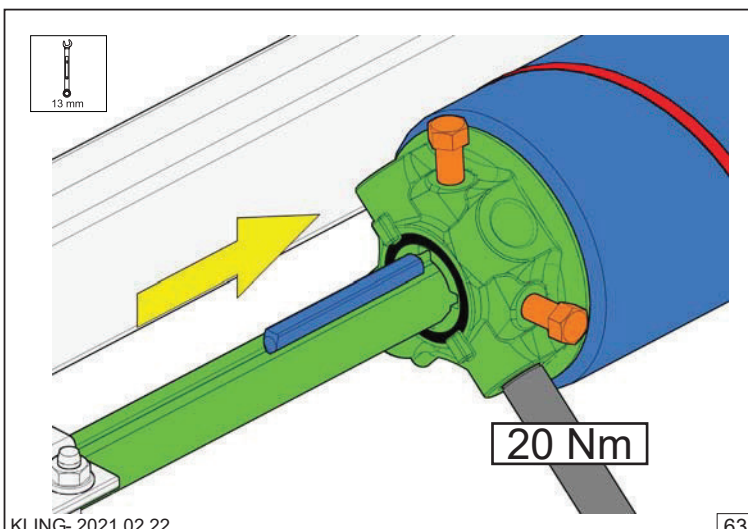

KLING- 2021.02.22.

63

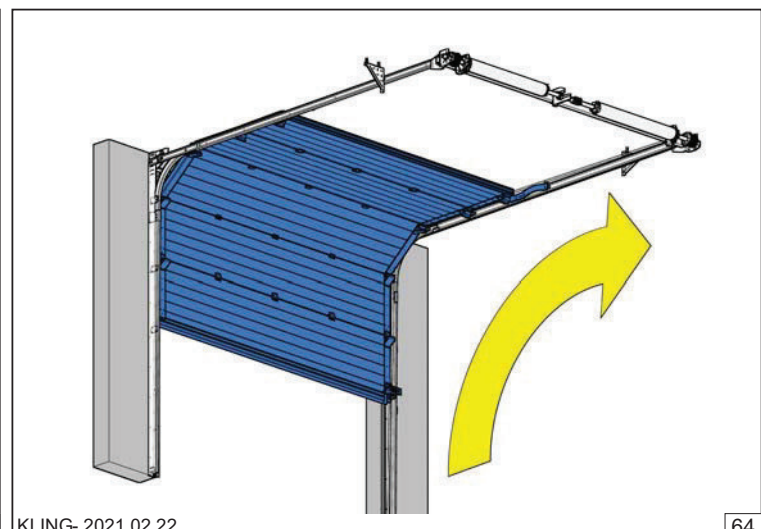

KLING- 2021.02.22.

64

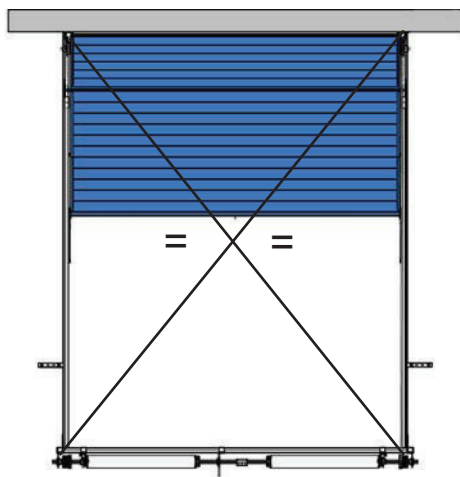

KLING- 2021.02.22.

65

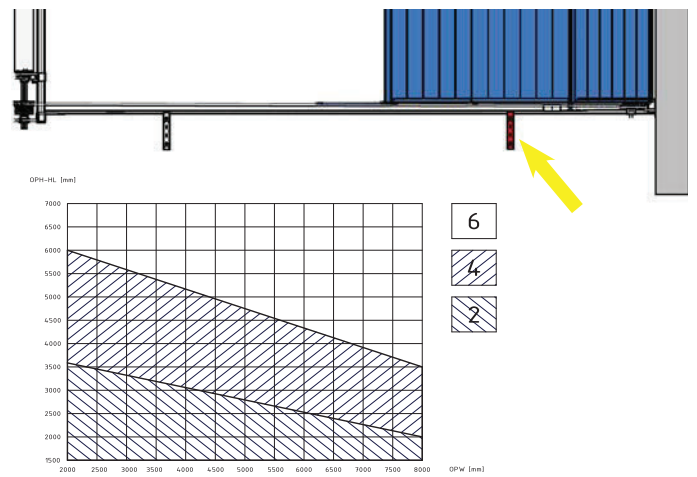

KLING- 2021.02.22.

66

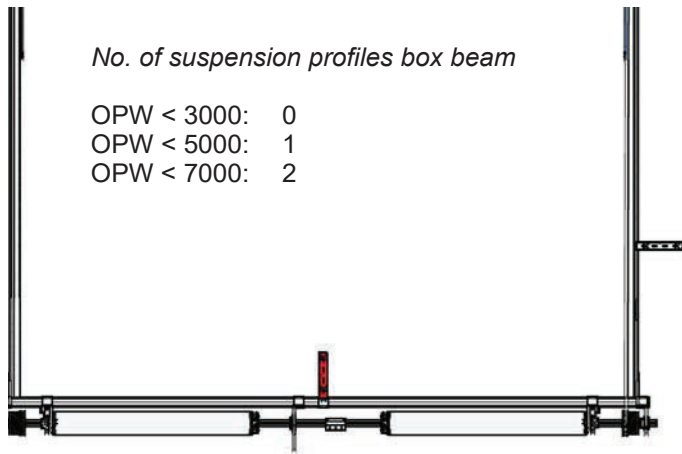

KLING- 2021.02.22.

67

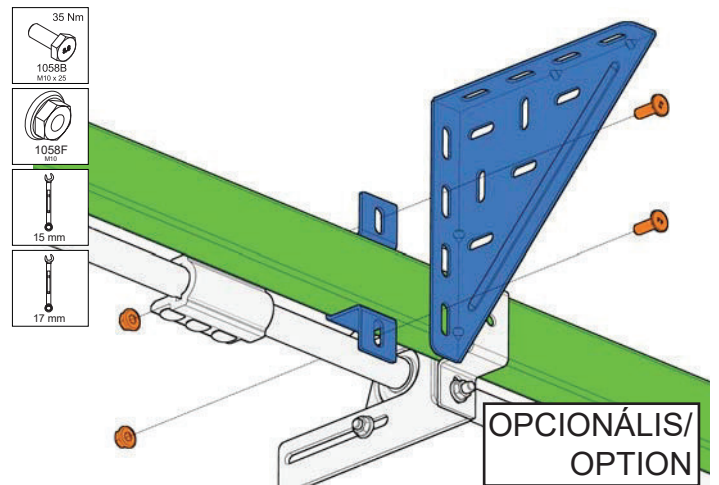

KLING- 2021.02.22.

68

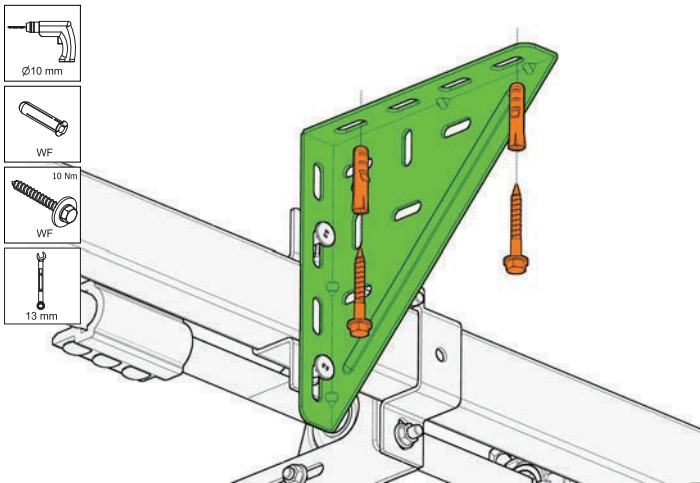

KLING- 2021.02.22.

69

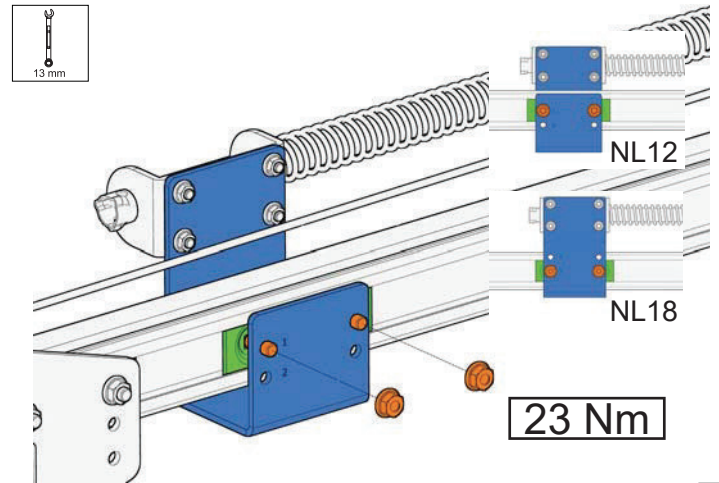

KLING- 2021.02.22.

70

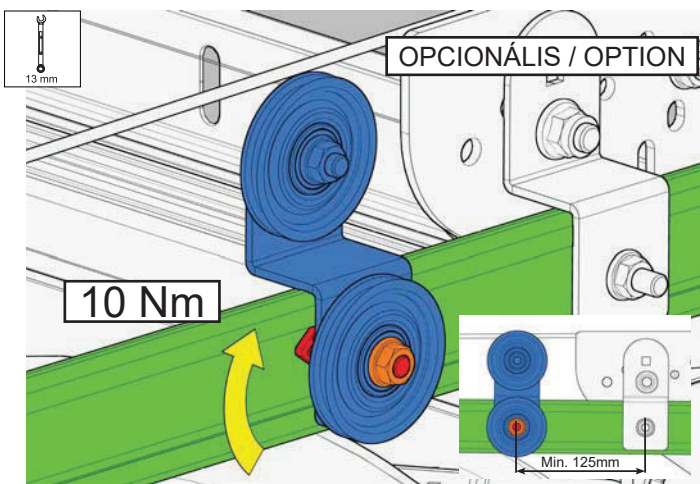

KLING- 2021.02.22.

71

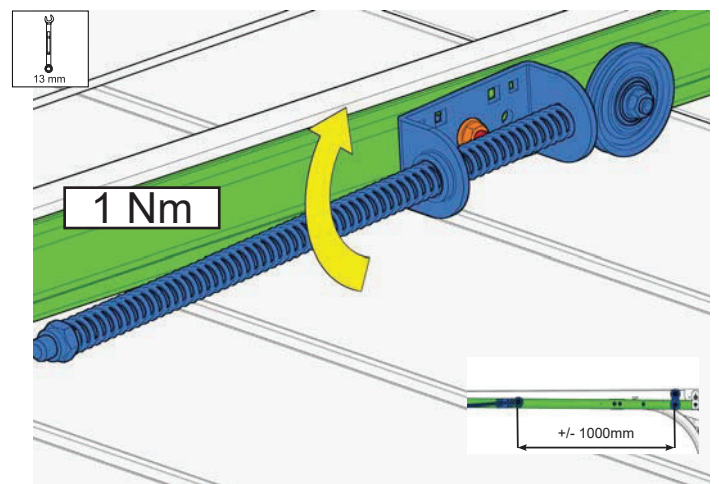

KLING- 2021.02.22.

72

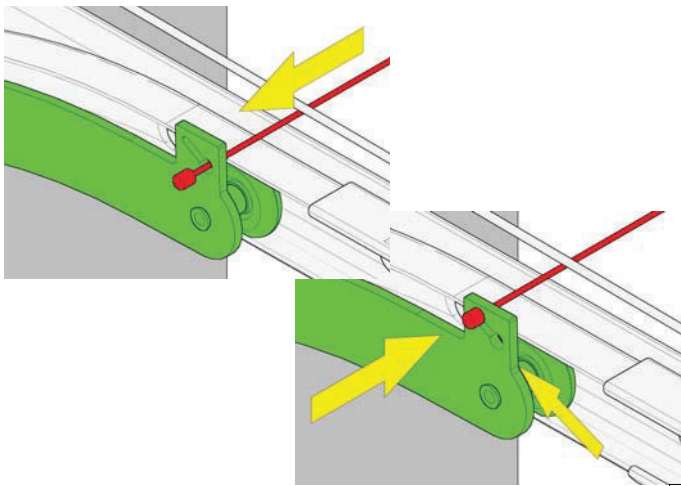

KLING- 2021.02.22.

73

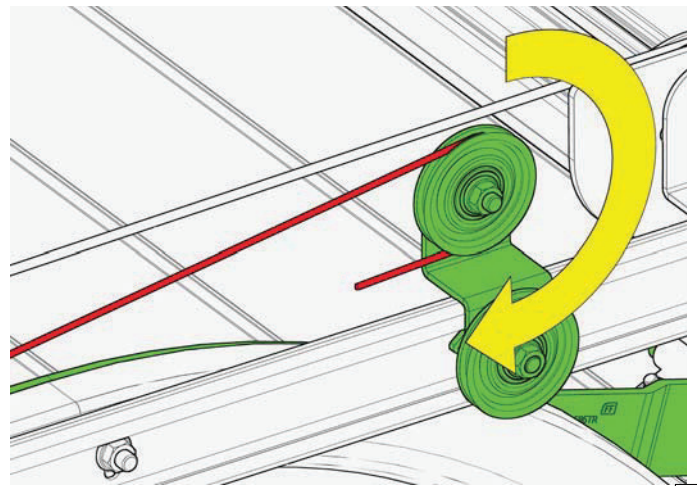

KLING- 2021.02.22.

74

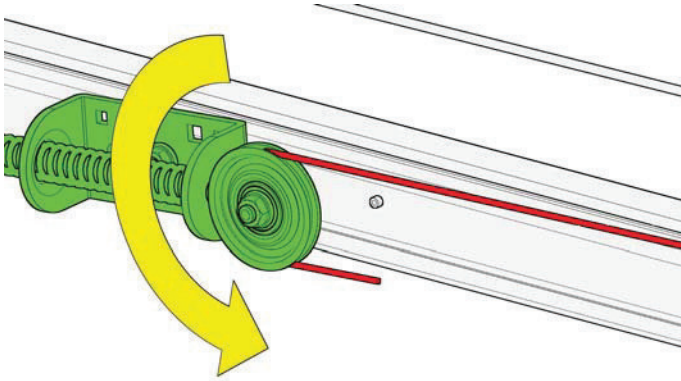

KLING- 2021.02.22.

75

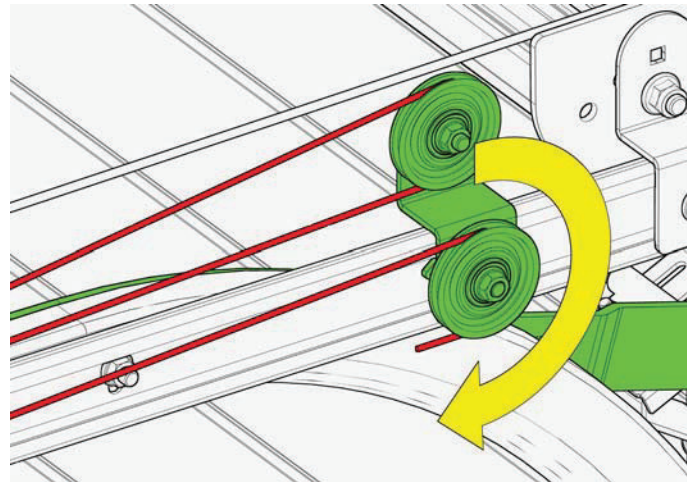

KLING- 2021.02.22.

76

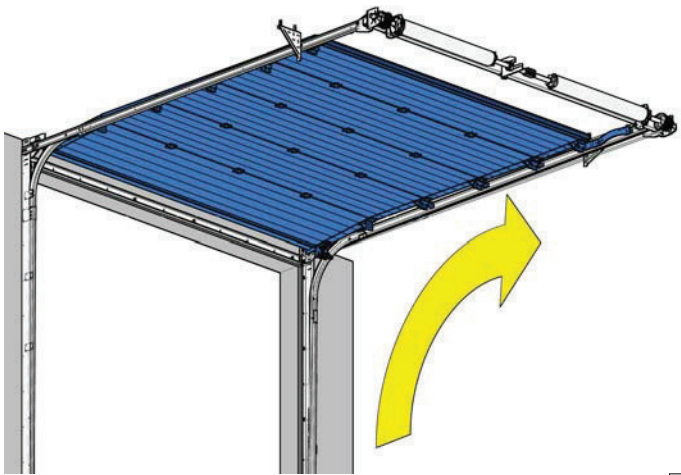

KLING- 2021.02.22.

77

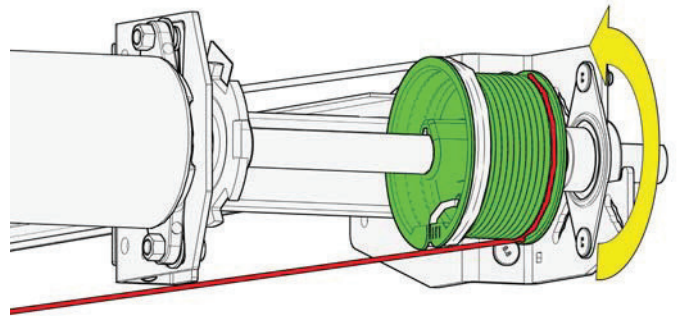

KLING- 2021.02.22.

78

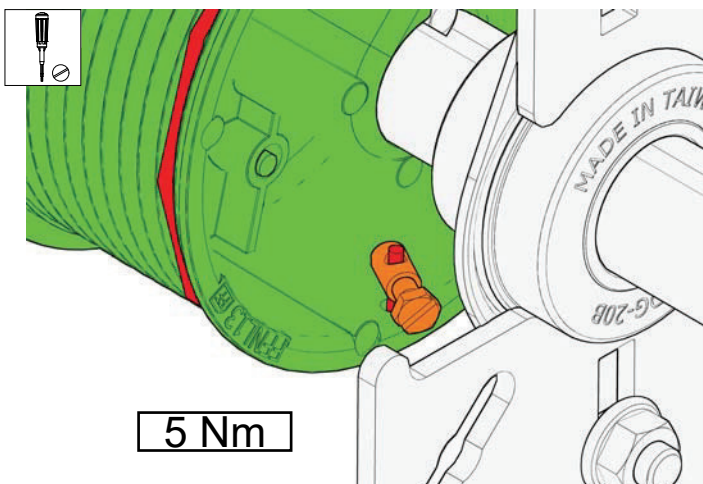

KLING- 2021.02.22.

79

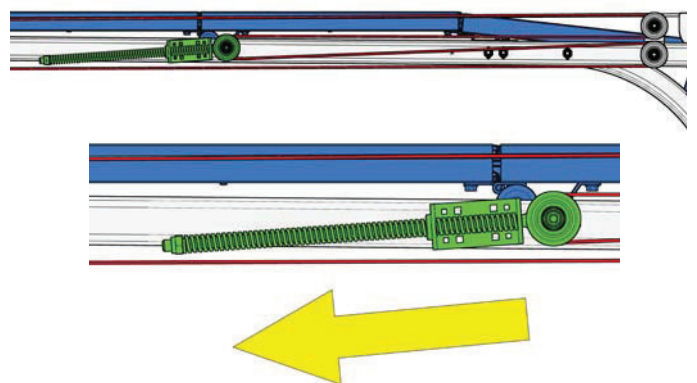

KLING- 2021.02.22.

80

MAXIMUM / MAX

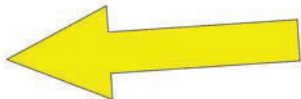

KLING- 2021.02.22.

81

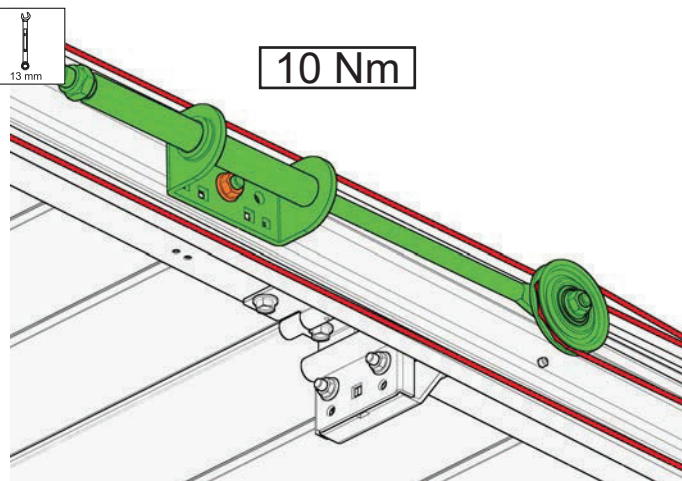

10 Nm

KLING- 2021.02.22.

82

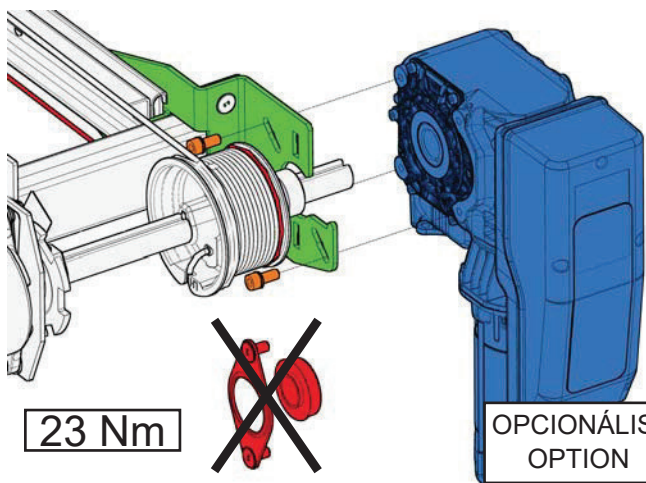

23 Nm

OPCIONÁLIS/
OPTION

KLING- 2021.02.22.

83

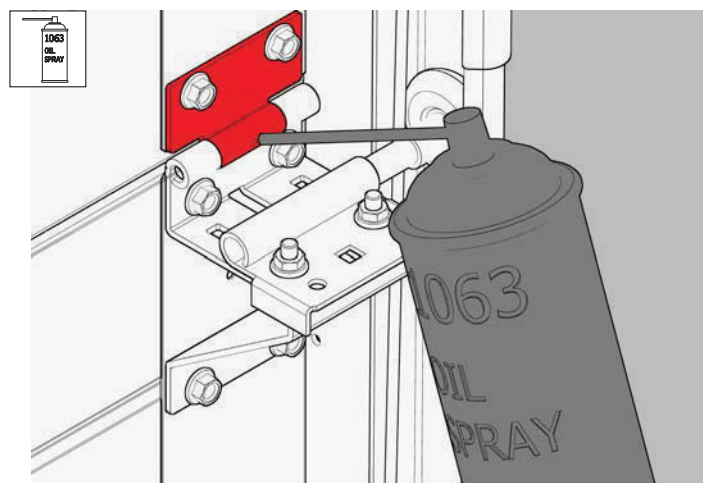

KLING- 2021.02.22.

84



KLING- 2021.02.22.

85

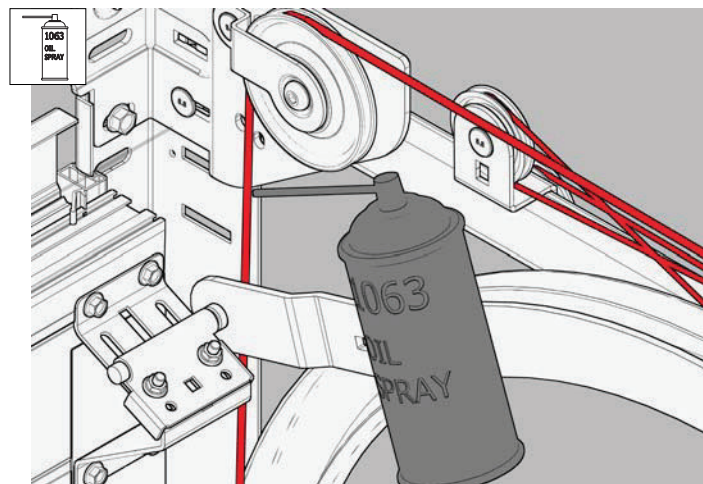

KLING- 2021.02.22.

86

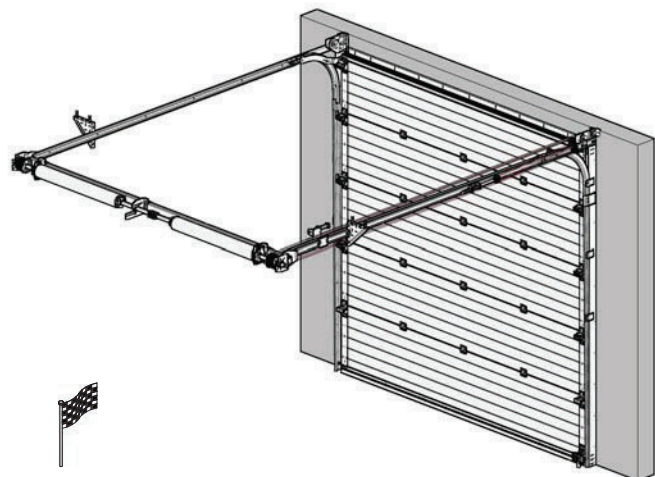

KLING- 2021.02.22.

87

KLING

Kling Kft. 1106 Budapest, Gránátos u. 6.
Copyright © Minden jog fenntartva.
Tel.: (+36 1) 433-1666
Fax: (+36 1) 262-2808

Nyitva tartás:
H – CS 7:00 – 16:00
P 7:00 – 15:00

E-mail:
contact@kling.hu



www.kling.hu